

C/E22 N - C/E32 N



C/E22 N



Sistema Enterprise



Sistema Unger S3



Sistema Unger S5



C/E22 N - C/E32 N

TRITACARNE DA BANCO 22-32 IN ACCIAIO INOX. Per medie e alte produzioni. Macchine robuste, affidabili, compatte, facili da pulire. Per macellerie, supermercati, laboratori carni, ristorazione, ...

- Costruzione compatta ed elegante in acciaio inox AISI 304
- Tramoggia estraibile inox AISI 304
- Bocca in acciaio inox AISI 304, facilmente smontabile per la pulizia:

Enterprise: 1 piastra ed 1 coltello in acciaio inox, autoaffilanti
Unger: 3 pezzi (Ø 82 mm) e 5 pezzi (Ø 98 mm)
 • Pulsanti di marcia e arresto a 24V, sistema NVR.
 • Dispositivo di inversione marcia
 • Pulizia semplice e veloce
 • Macchina conforme alle norme CE in materia di igiene e sicurezza e alle norme specifiche per i tritacarne

A richiesta

- Voltaggi speciali, 60Hz

STAINLESS STEEL TABLE TOP MEAT MINCER 22-32. For medium and large production; rugged, reliable, compact, easy to clean. Machines suitable for butcher shops, supermarkets, meat processing centres, catering industry, ...

- Styled and compact construction in stainless steel AISI 304
 - AISI 304 stainless steel removable feed pan
 - AISI 304 stainless steel head, readily disassembled for easy cleaning:
- Enterprise:** 1 self sharpening plate and 1 stainless steel knife
Unger: model 22 is available in 3 piece and 5 piece versions (Ø 82 mm) model 32 is available in a 5 piece version (Ø 98 mm)
 • Start and stop push button at 24V, NVR system.
 • Reverse device
 • Easy and fast cleaning
 • The machine has been designed in compliance with the CE norms on hygiene and safety and with specific requirement for mincing machines

On request

- Special voltages, 60Hz

HACHOIR A VIANDE EN ACIER INOX 22-32 DU COMPTOIR. Pour moyennes et hautes productions. Machines robustes, fiables, compactes, supermarchés, centres de transformation des viandes, restauration, ...

- Construction solide et de forme élégante en acier inox AISI 304
 - Trémie amovible en acier inox AISI 304
 - Bouche en acier inox AISI 304 démontable rapidement pour faciliter le nettoyage:
- Enterprise:** 1 plaque et 1 couteau en acier inox autoaffutants
Unger: à 3 pièces et à 5 pièces pour le model 22 (Ø 82 mm) et à 5 pièces pour le model 32 (Ø 98 mm)
 • Marche avant et arrêt à 24V - NVR système
 • Dispositif d'inversion de marche
 • Nettoyage simple et rapide
 • Machine conforme aux normes CE en matière d'hygiène et de sécurité, et aux normes spécifiques concernano les hachoirs

Sur demande

- Tension particulière, 60Hz

FLEISCHWOLF AUS ROSTFREIEM STAHL 22-32 TISCHMODELL. Für mittlere bis hohe Produktionen; robuste, zuverlässige, kompakte und leicht zu reinigen Maschinen. Für Metzgereien, Supermärkte, Fleisch verarbeitende Betriebe, Gastgewerbe, ...

- Formschöne und kompakte Konstruktion aus rostfreiem Stahl AISI 304
 - Ausziehbarer Trichter aus inox Stahl AISI 304
 - Schneckengehäuse aus Rostfreiem Stahl AISI 304, die leicht abnehmbar für die Reinigung ist:
- Enterprise:** 1 Lochschelbe und 1 selbstschärfendes Edelstahlmesser
Unger: 3 teilig (Ø 82 mm) und 5 teilig (Ø 98 mm)
 • Volwärtsgang. Stoppaste mit 24V, NVR System.
 • Rückwärtsvorrichtung
 • Einfache und schnelle Reinigung
 • Maschine mit den CE Normen betreffend Hygiene und Sicherheit, sowie den spezifischen Normen für Fleischwölfe konform

Auf Anfrage

- Sonderspannungen, 60Hz

PICADORA DE CARNE EN ACERO INOX 22-32. Para medianas y altas producciones; máquinas robustas, fiables, compactas, fáciles a limpiar. Para carnicerías, supermercados, laboratorios carnes, hostelería, ...

- Construcción en acero inox AISI 304 elegante y sólida
- Tolva extraíble de acero inox AISI 304
- Boca: de acero inox AISI 304:

Enterprise: 1 placa y 1 cuchillo de acero inoxidable autofiladores

- Unger:** de 3 piezas y 5 piezas el 22 (Ø 82 mm) y de 5 piezas el 32 (Ø 98 mm)
- Marcha avante y parade con 24V, sistema NVR.
- Marcha atrás
- Limpieza simple y rapida
- Máquina conforme a las normas CE, en materia de higiene y seguridad y a las normas específicas para las máquinas de picar carne

Bajo pedido

- Voltajes especiales, 60Hz

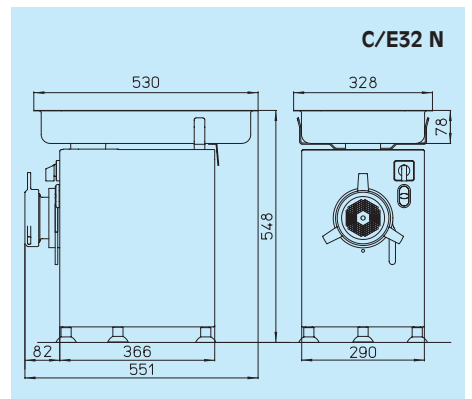
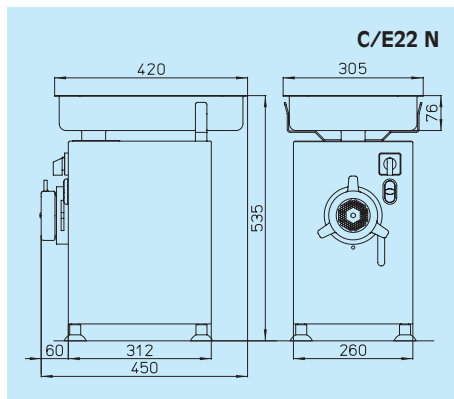

		C/E22 N	C/E32 N
Bocca - Head - Bouche - Gehäuse - Boca		22/82	32/98
Produzione oraria - Hourly output - Production horarje - Stundenleistung - Producción horaria	kg	300	500
Motore trifase - theephase motor - Moteur triphase - Dreiphasig Motor - Motor trifásico	kW (HP)	1.1 (1.5)	2.2 (3)
Motore monofase - singlephase motor - Moteur monophasé - Einphasig Motor - Motor monofásico	kW (HP)	1.1 (1.5)	2.2 (3)
Peso netto TF(MF) - Net weight TPH(SPH) - Poids net TPH(MN) - Nettogewicht DPH(EPH) - Peso Neto TF(MF)	kg	32 (33)	44 (50)



REG. N. 2714 UNI EN ISO 9001:2000



la Minerva di Chiodini Mario s.r.l.
 via del Vetraio, 36 - Z.I. Roveri 2 - 40138 Bologna - Italy
 tel. +39 051 530.174 - fax +39 051 535.327
 laminerva@laminerva.it
 www.laminerva.it

